

ANDREW K & ANN ALTEIN GRADY

APARTMENT A

5

FLOOR PLAN

BLDG. PERMIT PLANS

FILE COPY OF RECORD

MIKE BLEM

EMBLEM CONST.

#CQC 1508400

P.O. BOX 400

NOKOMIS IL 34274

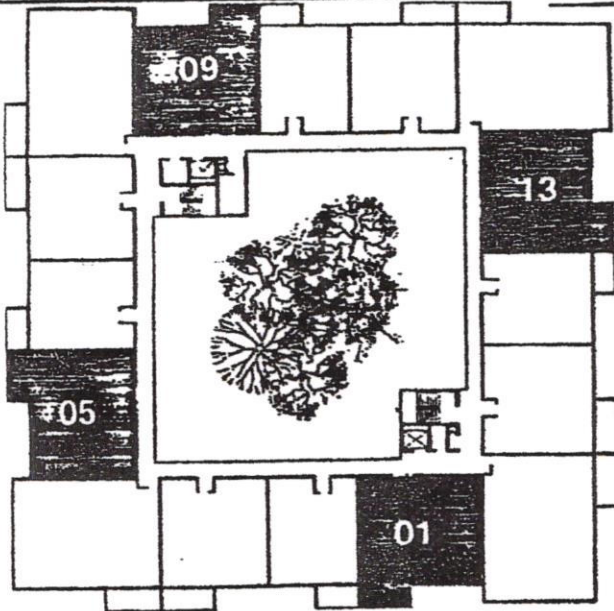

TYPICAL PLAN, FLOORS 2-5

REMODEL COMPLIES

WITH FBC 2020

LEV 2 ALT

7TH EDITION

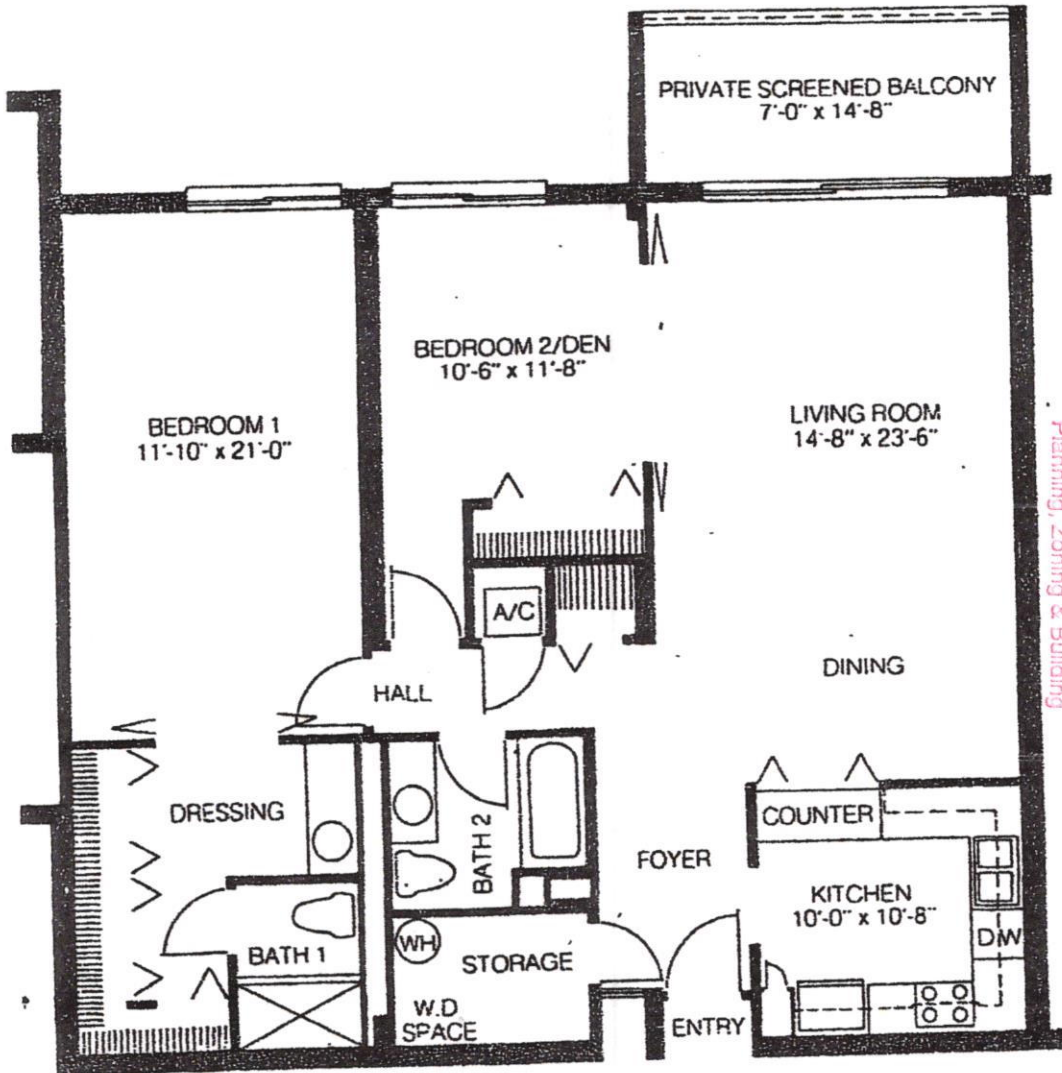

TOWN OF LONGBOAT KEY  
Planning, Zoning & Building

APR 06 2023

RECEIVED

Room dimensions are approximate For exact dimensions refer to condominium documents.

ANDREW K & ANN A HEARN GLENG

APARTMENT A  
S

DEMOLITION PLAN

BLDG PERMIT PLANS

MIKE BLEW FILE COPY OF RECORD

EMBLEM CONSTRUCTION

#CGC 150B400

P.O. BOX 400

NO 1100115 FC 34274

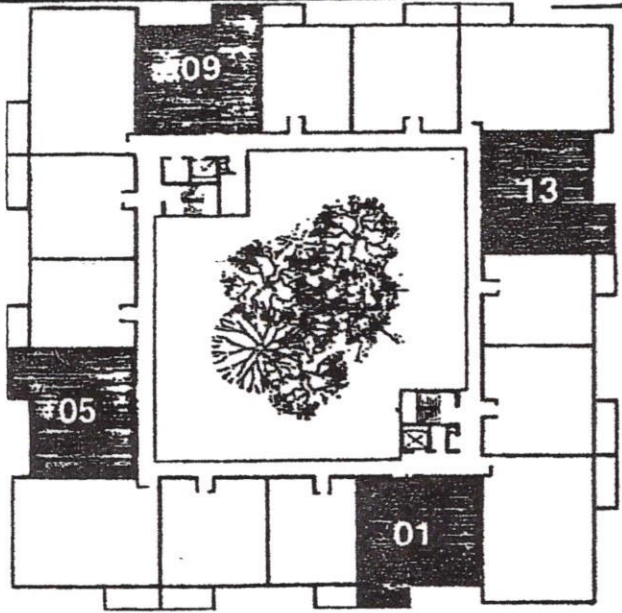

TYPICAL PLAN, FLOORS 2-5

MEMORANDUM COMPLIES WITH FBC 2010 7TH EDITION

RECEIVED  
APR 06 2013  
TOWN OF LONGBOAT KEY  
Planning, Zoning & Building

REMOVE DOORS & CASINGS

E

REMOVE DOOR & PARTIAL WALL

REMOVE WALLS & CLOSET HEADERS & CLOSET COLUMN

REMOVE TRAP

REMOVE CABINETS & TRAYS

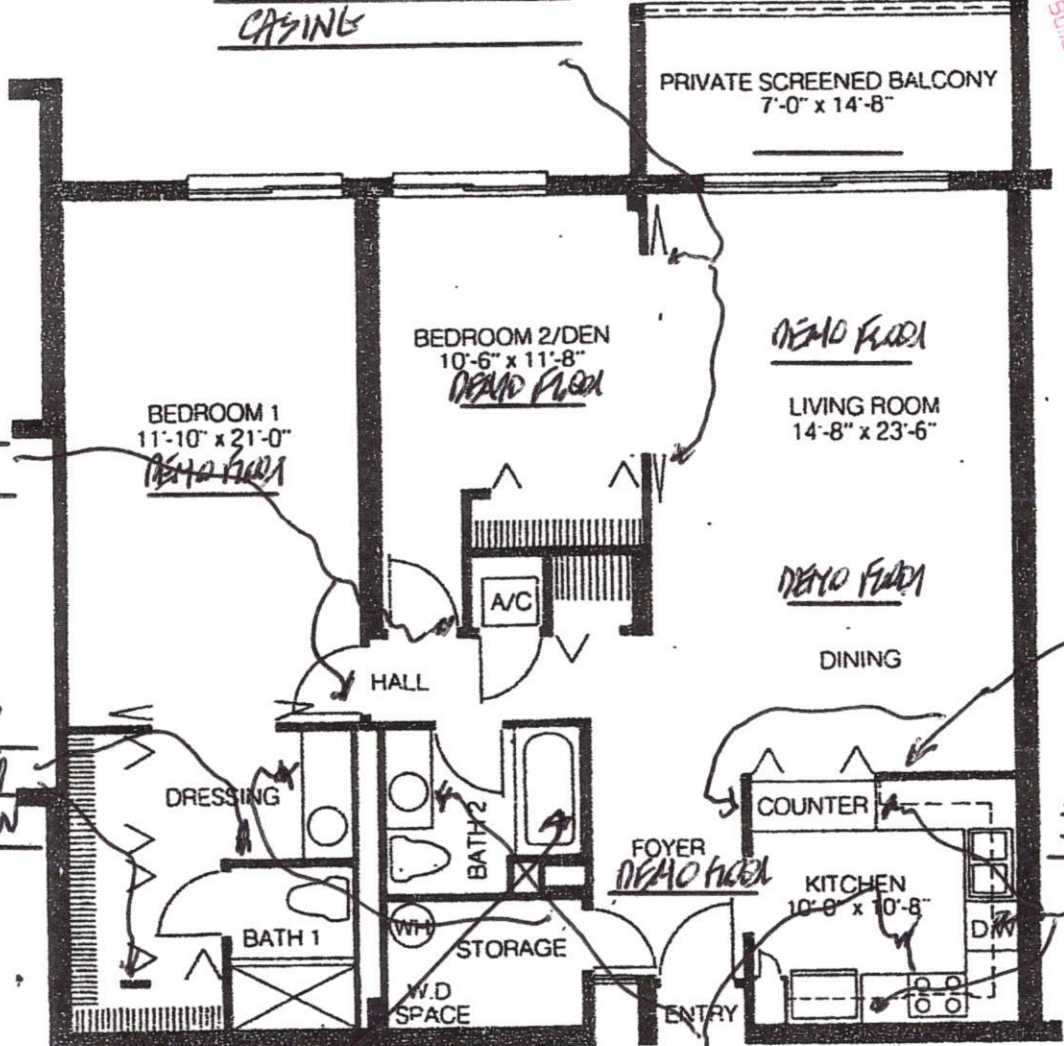

N

Room dimensions are approximate For exact dimensions refer to condominium documents.



ANDREW & ANN AHEARN GLINA

RECEIVED

APR 06 2023  
TOWN OF LONGBOAT KEY  
Planning, Zoning & Building

REMODEL COMPLIES  
WITH FBC 2020  
7TH EDITION

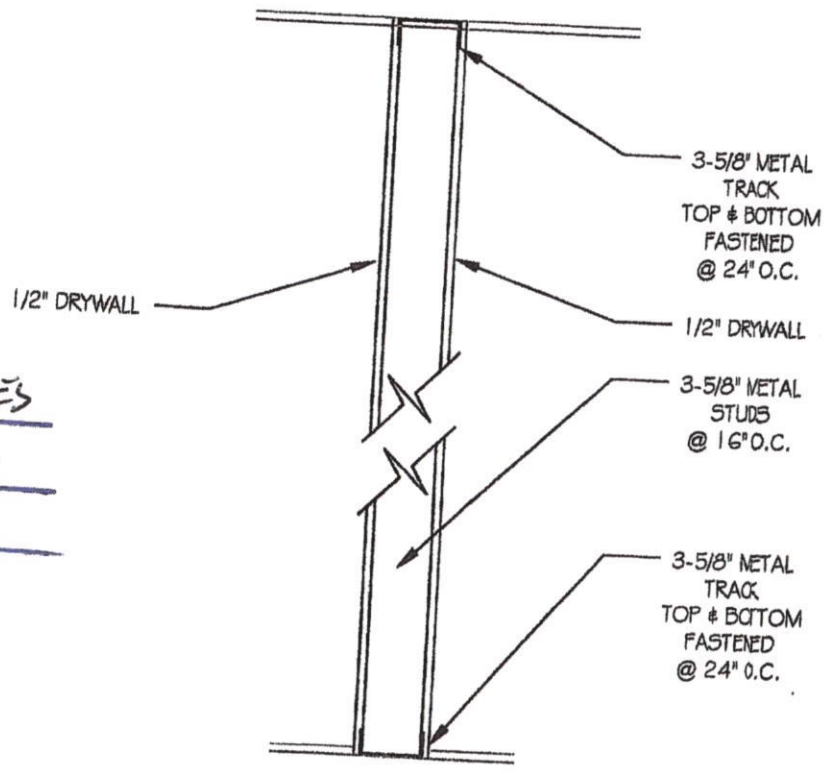

MIKE BLEH  
EMBLEM CONSTRUCTION  
#CEC 150B400  
P.O. BOX 400  
NOKOMIS FL 34274

TYP. INTERIOR WALL  
NON LOAD BEARING

SECTION DETAIL

SCALE: 1" = 1'-0"

ANDREW K + ANN AHEIN GLAUS

APARTMENT A

5

NEW WALL PLAN

BLDG. PERMIT PLANS

FILE COPY OF RECORD

MIKE BLETT

EMPLEN CONSTRUCTION

#CGC 1508400

P.O. BOX 400

NO. 10115 FE 34274

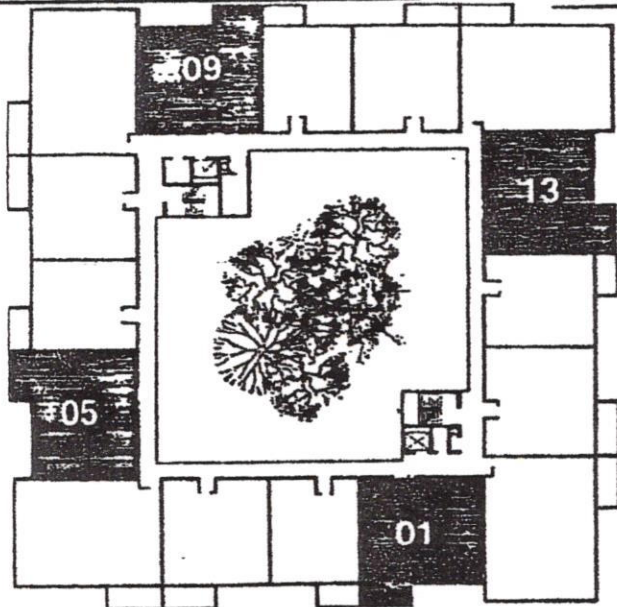

TYPICAL PLAN. FLOORS 2-5

REMODEL COMPLIES  
 WITH IBC 2020  
 7TH EDITION

RECEIVED

APR 06 2023

TOWN OF LONGBOAT KEY  
Planning, Zoning & Building

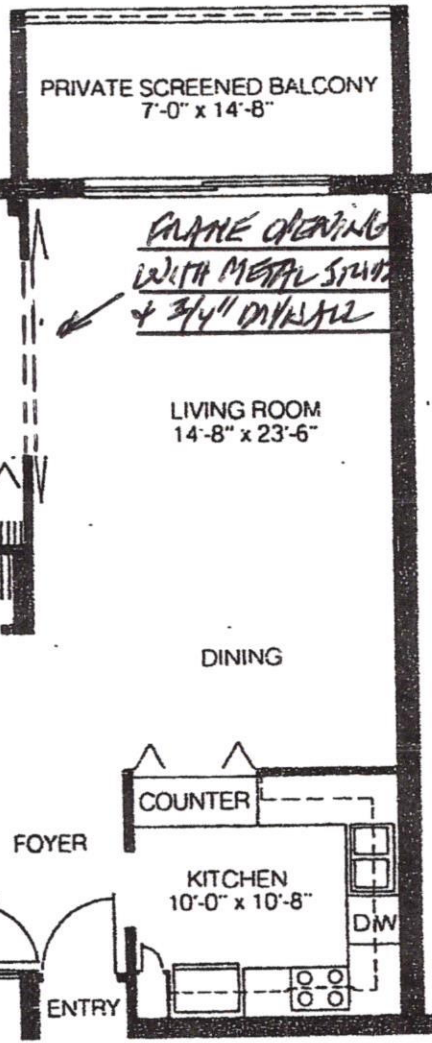

NEW CLOSET  
 THROUGH ENTRANCE  
 WITH METAL STUDS  
 + 3/4" DAYWALL

FRAME OPENING  
 WITH METAL STUDS  
 + 3/4" DAYWALL

Room dimensions are approximate. For exact dimensions refer to condominium documents.



ANDREW 169 ANN AHEAN GLANDS APARTMENT A S

SMOKE DETECTOR PLAN

BLDG. PERMIT PLANS

FILE COPY OF RECORD

MIKE AHEAN

EMBLEM CONSTRUCTION

#CGC 150B400

P.O. BOX 400

NDKDMIS FE 34274

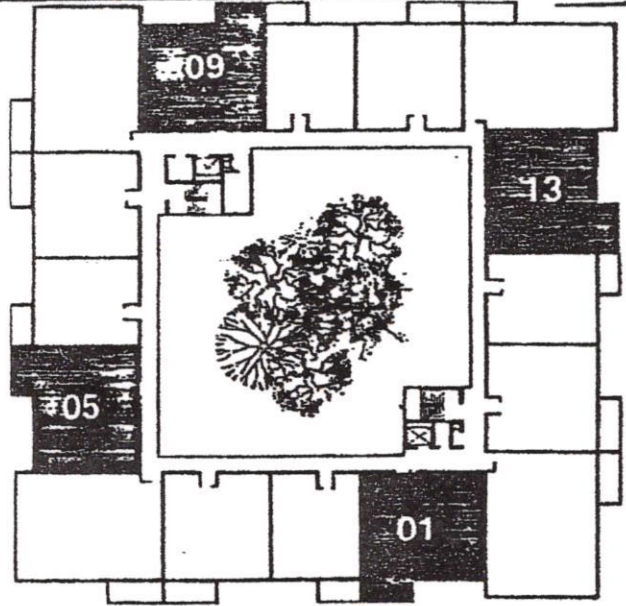

TYPICAL PLAN, FLOORS 2-5

REMODEL COMPLIES WITH FBC 2020 7TH EDITION

SM SMOKE DETECTOR

E

W

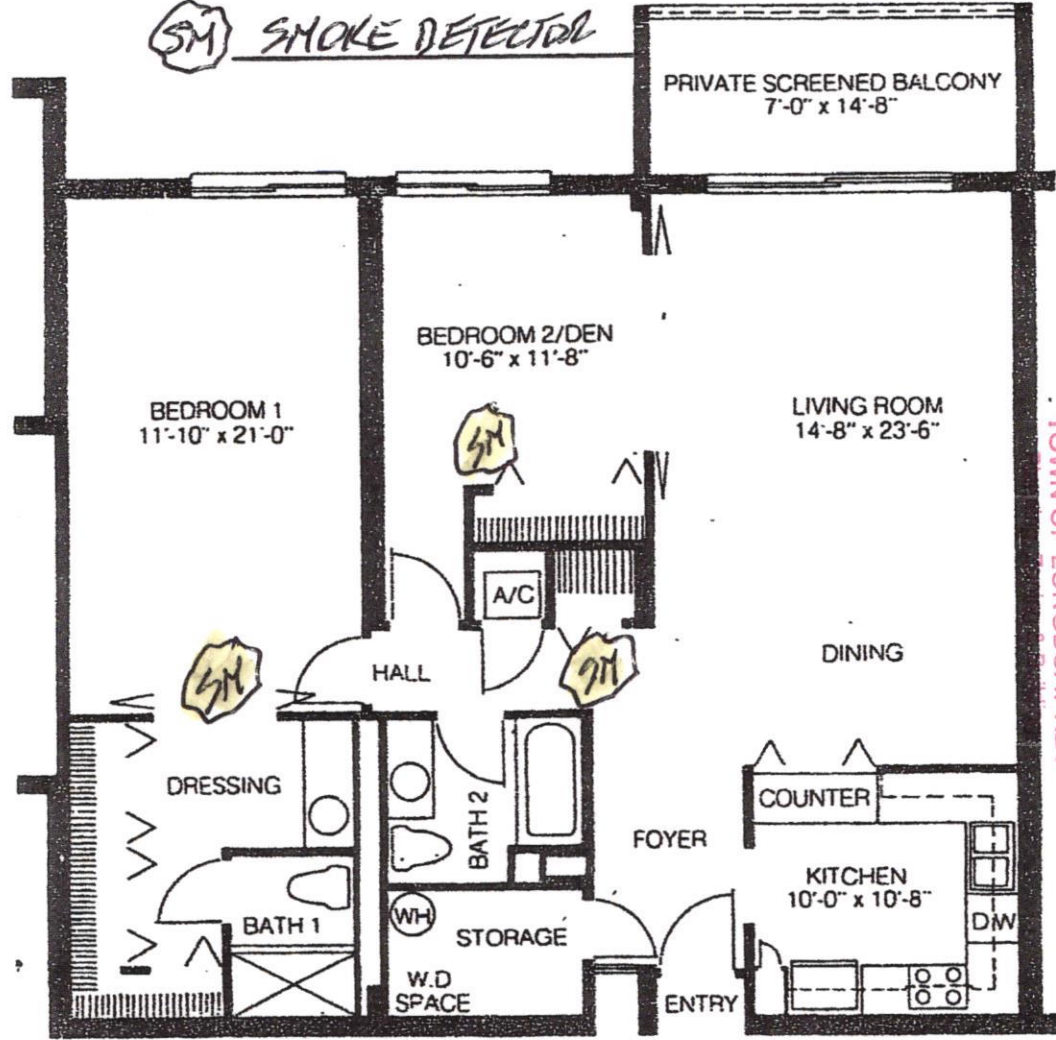

TOWN OF LONGBOAT KEY

APR 06 2023

RECEIVED

N

Room dimensions are approximate For exact dimensions refer to condominium documents.

REMOVED + NEW ATTEN GRABER

S

RECEIVED

APR 06 2023

TOWN OF LONGBOAT KEY  
Planning, Zoning & Building

ELECTRIC PLAN

- \* OUTLET
- # GF1 OUTLET
- # SWITCH
- Ø CHL UNIT

\* ALL ELECTRICAL  
DONE ACCORDING TO  
NEC 2020  
ELECTRICAL CODES

KITCHEN  
FLOOR PLAN  
SCALE: 3/8" = 1'-0"

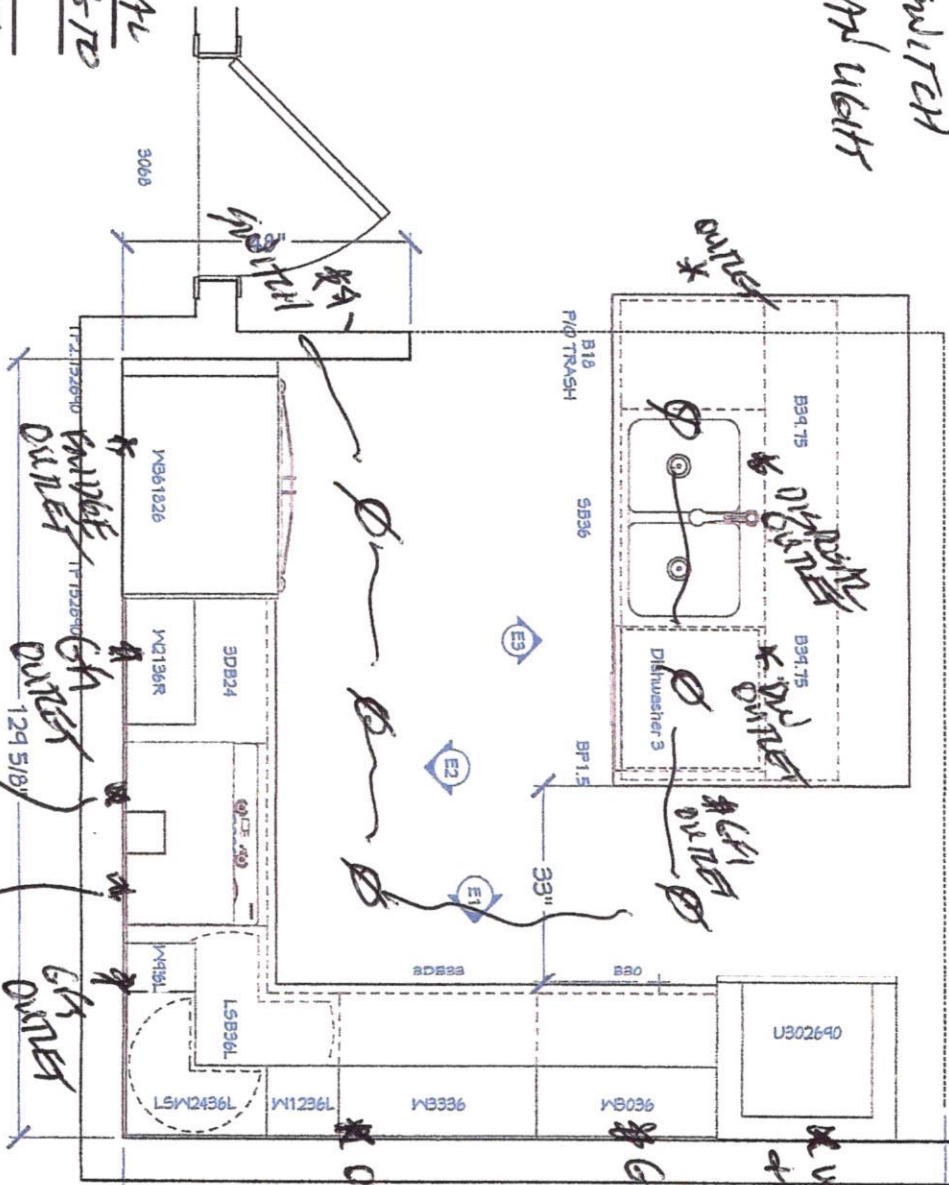

N

W

MILK BUSH  
ENERGY CONSTRUCTION  
# C&C 1508400  
P.O. BOX 400  
NORFOLK IS 234274



ADD 12' x 14' ANTENNA GAP'S

BLDG. PERMIT PLAN  
FILE COPY OF RECORD

S

RECEIVED

APR 06 2003

TOWN OF LONGBOAT KEY  
Planning, Zoning & Building

FINAL WITHDRAWN KEY  
PLAN

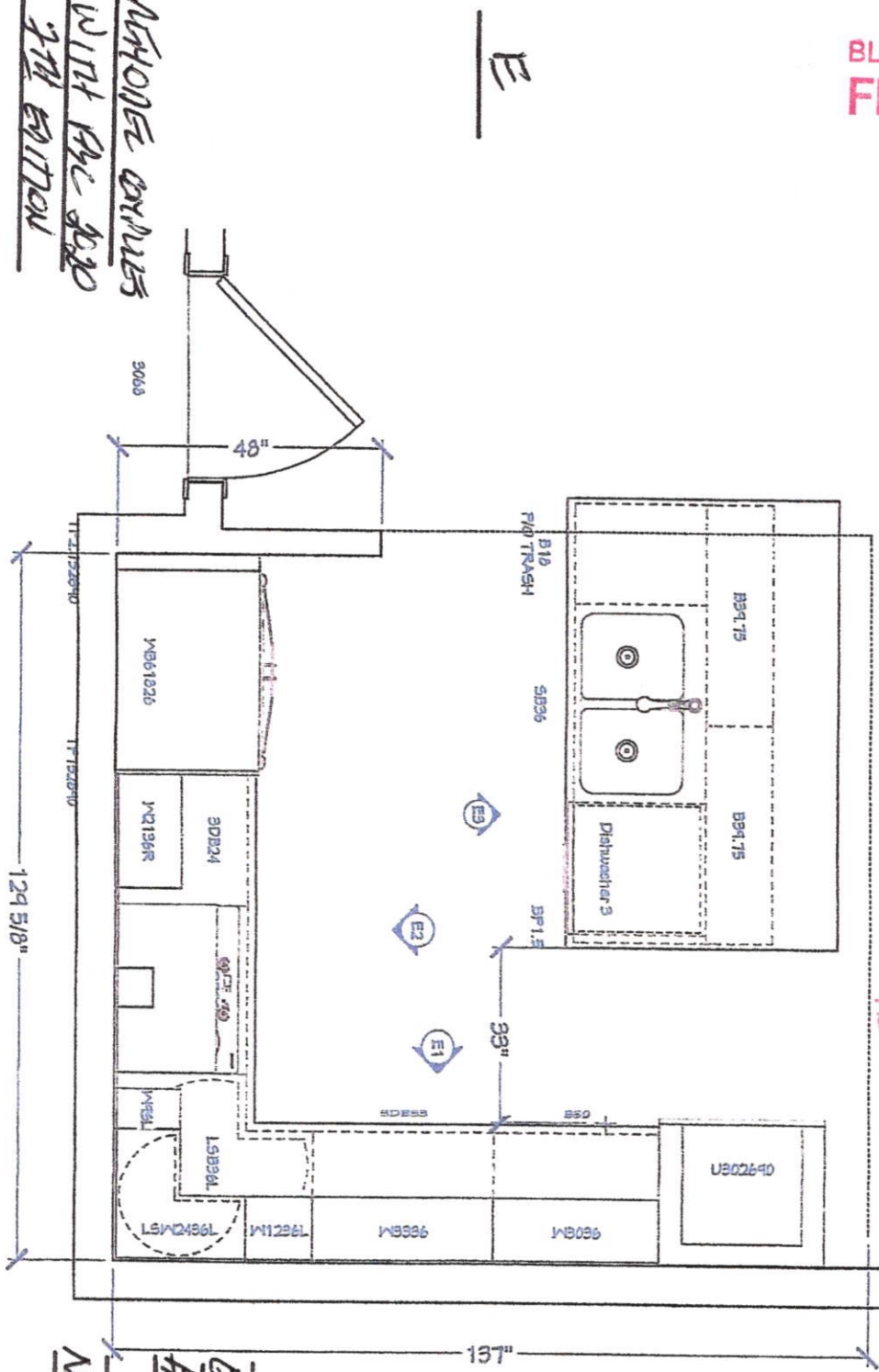

ANYONE OPINES  
WITH THE 30 5/8"  
3RD EDITION

MIKE BLEW  
EVALEEN CONST.  
# CGL 1508400  
P.O. BOX 400  
NOLKONIS FL 34274