

JP 34358

# ELEVATION CERTIFICATE

**Important:** Follow the instructions on pages 1-9.

Copy all pages of this Elevation Certificate and all attachments for (1) community official, (2) insurance agent/company, and (3) building owner.

SECTION A - PROPERTY INFORMATION				FOR INSURANCE COMPANY USE	
A1. Building Owner's Name Michael Patneuade				Policy Number:	
A2. Building Street Address (including Apt., Unit, Suite, and/or Bldg. No.) or P.O. Route and Box No. 641 Emerald Harbor Dr.				Company NAIC Number:	
City Longboat Key		State Florida		ZIP Code 34229	
A3. Property Description (Lot and Block Numbers, Tax Parcel Number, Legal Description, etc.) Lot 40 Dream Island					
A4. Building Use (e.g., Residential, Non-Residential, Addition, Accessory, etc.) <u>Residential</u>					
A5. Latitude/Longitude: Lat. <u>N 27.421986</u> Long. <u>W 82.666513</u> Horizontal Datum: <input type="checkbox"/> NAD 1927 <input checked="" type="checkbox"/> NAD 1983					
A6. Attach at least 2 photographs of the building if the Certificate is being used to obtain flood insurance.					
A7. Building Diagram Number <u>1B</u>					
A8. For a building with a crawlspace or enclosure(s):					
a) Square footage of crawlspace or enclosure(s) <u>0</u> sq ft					
b) Number of permanent flood openings in the crawlspace or enclosure(s) within 1.0 foot above adjacent grade _____					
c) Total net area of flood openings in A8.b <u>0</u> sq in					
d) Engineered flood openings? <input type="checkbox"/> Yes <input type="checkbox"/> No					
A9. For a building with an attached garage:					
a) Square footage of attached garage <u>1,119</u> sq ft					
b) Number of permanent flood openings in the attached garage within 1.0 foot above adjacent grade <u>7</u>					
c) Total net area of flood openings in A9.b <u>896</u> sq in					
d) Engineered flood openings? <input checked="" type="checkbox"/> Yes <input type="checkbox"/> No					
SECTION B - FLOOD INSURANCE RATE MAP (FIRM) INFORMATION					
B1. NFIP Community Name & Community Number Longboat Key, Town Of 125126			B2. County Name Manatee		B3. State Florida
B4. Map/Panel Number 12081C0291	B5. Suffix E	B6. FIRM Index Date 03/17/2014	B7. FIRM Panel Effective/ Revised Date 03/17/2014	B8. Flood Zone(s) AE	B9. Base Flood Elevation(s) (Zone AO, use Base Flood Depth) 10
B10. Indicate the source of the Base Flood Elevation (BFE) data or base flood depth entered in Item B9: <input type="checkbox"/> FIS Profile <input checked="" type="checkbox"/> FIRM <input type="checkbox"/> Community Determined <input type="checkbox"/> Other/Source: _____					
B11. Indicate elevation datum used for BFE in Item B9: <input type="checkbox"/> NGVD 1929 <input checked="" type="checkbox"/> NAVD 1988 <input type="checkbox"/> Other/Source: _____					
B12. Is the building located in a Coastal Barrier Resources System (CBRS) area or Otherwise Protected Area (OPA)? <input type="checkbox"/> Yes <input checked="" type="checkbox"/> No Designation Date: _____ <input type="checkbox"/> CBRS <input type="checkbox"/> OPA					

RECEIVED

NOV 07 2017

# ELEVATION CERTIFICATE

OMB No. 1660-0008  
Expiration Date: November 30, 2018

<b>IMPORTANT: In these spaces, copy the corresponding information from Section A.</b>			<b>FOR INSURANCE COMPANY USE</b>
Building Street Address (including Apt., Unit, Suite, and/or Bldg. No.) or P.O. Route and Box No. 641 Emerald Harbor Dr.			Policy Number:
City Longboat Key	State Florida	ZIP Code 34229	Company NAIC Number

## SECTION C – BUILDING ELEVATION INFORMATION (SURVEY REQUIRED)

C1. Building elevations are based on:  Construction Drawings\*  Building Under Construction\*  Finished Construction  
\*A new Elevation Certificate will be required when construction of the building is complete.

C2. Elevations – Zones A1–A30, AE, AH, A (with BFE), VE, V1–V30, V (with BFE), AR, AR/A, AR/AE, AR/A1–A30, AR/AH, AR/AO. Complete Items C2.a–h below according to the building diagram specified in Item A7. In Puerto Rico only, enter meters.

Benchmark Utilized: NGS BM W 689 Vertical Datum: 4.55

Indicate elevation datum used for the elevations in items a) through h) below.

NGVD 1929  NAVD 1988  Other/Source: \_\_\_\_\_

Datum used for building elevations must be the same as that used for the BFE.

Check the measurement used.

- |   |             |  |                                 |
|---|-------------|--|---------------------------------|
| a) Top of bottom floor (including basement, crawlspace, or enclosure floor)   | <u>11.6</u> | <input checked="" type="checkbox"/> feet | <input type="checkbox"/> meters |
| b) Top of the next higher floor   | <u>25.0</u> | <input checked="" type="checkbox"/> feet | <input type="checkbox"/> meters |
| c) Bottom of the lowest horizontal structural member (V Zones only)   | <u>N/A</u>  | <input checked="" type="checkbox"/> feet | <input type="checkbox"/> meters |
| d) Attached garage (top of slab)  | <u>7.1</u>  | <input checked="" type="checkbox"/> feet | <input type="checkbox"/> meters |
| e) Lowest elevation of machinery or equipment servicing the building<br>(Describe type of equipment and location in Comments) | <u>11.5</u> | <input checked="" type="checkbox"/> feet | <input type="checkbox"/> meters |
| f) Lowest adjacent (finished) grade next to building (LAG)  | <u>6.1</u>  | <input checked="" type="checkbox"/> feet | <input type="checkbox"/> meters |
| g) Highest adjacent (finished) grade next to building (HAG)   | <u>6.5</u>  | <input checked="" type="checkbox"/> feet | <input type="checkbox"/> meters |
| h) Lowest adjacent grade at lowest elevation of deck or stairs, including structural support                                  | <u>6.1</u>  | <input checked="" type="checkbox"/> feet | <input type="checkbox"/> meters |

## SECTION D – SURVEYOR, ENGINEER, OR ARCHITECT CERTIFICATION

This certification is to be signed and sealed by a land surveyor, engineer, or architect authorized by law to certify elevation information. I certify that the information on this Certificate represents my best efforts to interpret the data available. I understand that any false statement may be punishable by fine or imprisonment under 18 U.S. Code, Section 1001.

Were latitude and longitude in Section A provided by a licensed land surveyor?  Yes  No  Check here if attachments.

Certifier's Name James Burchett	License Number LS 5701	
Title President		
Company Name Sampey, Burchett and Knight, Inc.		
Address 1570 Global Court		
City Sarasota	State Florida	
Signature <i>James Burchett</i>	Date 10/27/2017	Telephone (941) 342-0349

Copy all pages of this Elevation Certificate and all attachments for (1) community official, (2) insurance agent/company, and (3) building owner.

Comments (including type of equipment and location, per C2(e), if applicable)

A9. 7 Flood vents Model #154-520, 200 sq. in. per vent for a total of 1400 sq. in.

C2.e) Air conditioner is on the North side of two car garage, East side of residence.

# ELEVATION CERTIFICATE

OMB No. 1660-0008  
Expiration Date: November 30, 2018

<b>IMPORTANT: In these spaces, copy the corresponding information from Section A.</b>			<b>FOR INSURANCE COMPANY USE</b>
Building Street Address (including Apt., Unit, Suite, and/or Bldg. No.) or P.O. Route and Box No. 641 Emerald Harbor Dr.			Policy Number:
City Longboat Key	State Florida	ZIP Code 34229	Company NAIC Number

**SECTION E – BUILDING ELEVATION INFORMATION (SURVEY NOT REQUIRED)  
FOR ZONE AO AND ZONE A (WITHOUT BFE)**

For Zones AO and A (without BFE), complete Items E1–E5. If the Certificate is intended to support a LOMA or LOMR-F request, complete Sections A, B, and C. For Items E1–E4, use natural grade, if available. Check the measurement used. In Puerto Rico only, enter meters.

- E1. Provide elevation information for the following and check the appropriate boxes to show whether the elevation is above or below the highest adjacent grade (HAG) and the lowest adjacent grade (LAG).
- a) Top of bottom floor (including basement, crawlspace, or enclosure) is \_\_\_\_\_  feet  meters  above or  below the HAG.
- b) Top of bottom floor (including basement, crawlspace, or enclosure) is \_\_\_\_\_  feet  meters  above or  below the LAG.
- E2. For Building Diagrams 6–9 with permanent flood openings provided in Section A Items 8 and/or 9 (see pages 1–2 of Instructions), the next higher floor (elevation C2.b in the diagrams) of the building is \_\_\_\_\_  feet  meters  above or  below the HAG.
- E3. Attached garage (top of slab) is \_\_\_\_\_  feet  meters  above or  below the HAG.
- E4. Top of platform of machinery and/or equipment servicing the building is \_\_\_\_\_  feet  meters  above or  below the HAG.
- E5. Zone AO only: If no flood depth number is available, is the top of the bottom floor elevated in accordance with the community's floodplain management ordinance?  Yes  No  Unknown. The local official must certify this information in Section G.

**SECTION F – PROPERTY OWNER (OR OWNER'S REPRESENTATIVE) CERTIFICATION**

The property owner or owner's authorized representative who completes Sections A, B, and E for Zone A (without a FEMA-issued or community-issued BFE) or Zone AO must sign here. The statements in Sections A, B, and E are correct to the best of my knowledge.

Property Owner or Owner's Authorized Representative's Name			
Address	City	State	ZIP Code
Signature	Date	Telephone	

Comments

Check here if attachments.

ELEVATION CERTIFICATE

OMB No. 1660-0008  
Expiration Date: November 30, 2018

<b>IMPORTANT: In these spaces, copy the corresponding information from Section A.</b>			<b>FOR INSURANCE COMPANY USE</b>
Building Street Address (including Apt., Unit, Suite, and/or Bldg. No.) or P.O. Route and Box No. 641 Emerald Harbor Dr.			Policy Number:
City Longboat Key	State Florida	ZIP Code 34229	Company NAIC Number

**SECTION G – COMMUNITY INFORMATION (OPTIONAL)**

The local official who is authorized by law or ordinance to administer the community's floodplain management ordinance can complete Sections A, B, C (or E), and G of this Elevation Certificate. Complete the applicable item(s) and sign below. Check the measurement used in Items G8–G10. In Puerto Rico only, enter meters.

- G1.  The information in Section C was taken from other documentation that has been signed and sealed by a licensed surveyor, engineer, or architect who is authorized by law to certify elevation information. (Indicate the source and date of the elevation data in the Comments area below.)
- G2.  A community official completed Section E for a building located in Zone A (without a FEMA-issued or community-issued BFE) or Zone AO.
- G3.  The following information (Items G4–G10) is provided for community floodplain management purposes.

G4. Permit Number	G5. Date Permit Issued	G6. Date Certificate of Compliance/Occupancy Issued
-------------------	------------------------	---

- G7. This permit has been issued for:     New Construction     Substantial Improvement
- G8. Elevation of as-built lowest floor (including basement) of the building: \_\_\_\_\_  feet  meters Datum \_\_\_\_\_
- G9. BFE or (in Zone AO) depth of flooding at the building site: \_\_\_\_\_  feet  meters Datum \_\_\_\_\_
- G10. Community's design flood elevation: \_\_\_\_\_  feet  meters Datum \_\_\_\_\_

Local Official's Name	Title
Community Name	Telephone
Signature	Date

Comments (including type of equipment and location, per C2(e), if applicable)

Check here if attachments.

# BUILDING PHOTOGRAPHS

See Instructions for Item A6.

OMB No. 1660-0008

Expiration Date: November 30, 2018

## ELEVATION CERTIFICATE

<b>IMPORTANT: In these spaces, copy the corresponding information from Section A.</b>			<b>FOR INSURANCE COMPANY USE</b>
Building Street Address (including Apt., Unit, Suite, and/or Bldg. No.) or P.O. Route and Box No. 641 Emerald Harbor Dr.			Policy Number:
City Longboat Key	State Florida	ZIP Code 34229	Company NAIC Number

If using the Elevation Certificate to obtain NFIP flood insurance, affix at least 2 building photographs below according to the instructions for Item A6. Identify all photographs with date taken; "Front View" and "Rear View"; and, if required, "Right Side View" and "Left Side View." When applicable, photographs must show the foundation with representative examples of the flood openings or vents, as indicated in Section A8. If submitting more photographs than will fit on this page, use the Continuation Page.



Photo One

Photo One Caption



Photo Two

Photo Two Caption

# BUILDING PHOTOGRAPHS

Continuation Page

OMB No. 1660-0008

Expiration Date: November 30, 2018

## ELEVATION CERTIFICATE

<b>IMPORTANT: In these spaces, copy the corresponding information from Section A.</b>			<b>FOR INSURANCE COMPANY USE</b>
Building Street Address (including Apt., Unit, Suite, and/or Bldg. No.) or P.O. Route and Box No. 641 Emerald Harbor Dr.			Policy Number:
City Longboat Key	State Florida	ZIP Code 34229	Company NAIC Number

If submitting more photographs than will fit on the preceding page, affix the additional photographs below. Identify all photographs with: date taken; "Front View" and "Rear View"; and, if required, "Right Side View" and "Left Side View." When applicable, photographs must show the foundation with representative examples of the flood openings or vents, as indicated in Section A8.



Photo One

Photo One Caption



Photo Two

Photo Two Caption



Most Widely Accepted and Trusted

# ICC-ES Report

## ESR-2074

ICC-ES | (800) 423-6587 | (562) 699-0543 | www.icc-es.org

Reissued 02/2015  
This report is subject to renewal 02/2017.

DIVISION: 08 00 00—OPENINGS

SECTION: 08 95 43—VENTS/FOUNDATION FLOOD VENTS

REPORT HOLDER:

**SMARTVENT PRODUCTS, INC.**

430 ANDBRO DRIVE, UNIT 1  
PITMAN, NEW JERSEY 08071

EVALUATION SUBJECT:

**SMART VENT® AUTOMATIC FOUNDATION FLOOD VENTS: MODELS #1540-520;  
#1540-521; #1540-510; #1540-511; #1540-570; #1540-574; #1540-524; #1540-514**



Look for the trusted marks of Conformity!

*"2014 Recipient of Prestigious Western States Seismic Policy Council (WSSPC) Award in Excellence"*



A Subsidiary of

*ICC-ES Evaluation Reports are not to be construed as representing aesthetics or any other attributes not specifically addressed, nor are they to be construed as an endorsement of the subject of the report or a recommendation for its use. There is no warranty by ICC Evaluation Service, LLC, express or implied, as to any finding or other matter in this report, or as to any product covered by the report.*



Copyright © 2016 ICC Evaluation Service, LLC. All rights reserved.

- Below the base flood elevation.
- With the bottom of the FV located a maximum of 12 inches (305.4 mm) above the higher of the final grade or floor and finished exterior grade immediately under each opening.

**5.0 CONDITIONS OF USE**

The Smart Vent® FVs described in this report comply with, or are suitable alternatives to what is specified in, those codes listed in Section 1.0 of this report, subject to the following conditions:

- 5.1 The Smart Vent® FVs must be installed in accordance with this report, the applicable code and the manufacturer's installation instructions. In the event of a conflict, the instructions in this report govern.

- 5.2 The Smart Vent® FVs must not be used in the place of "breakaway walls" in coastal high hazard areas, but are permitted for use in conjunction with breakaway walls in other areas.

**6.0 EVIDENCE SUBMITTED**

Data in accordance with the ICC-ES Acceptance Criteria for Mechanically Operated Flood Vents (AC364), dated August 2015.

**7.0 IDENTIFICATION**

The Smart VENT® models recognized in this report must be identified by a label bearing the manufacturer's name (Smartvent Products, Inc.), the model number, and the evaluation report number (ESR-2074).

TABLE 1—MODEL SIZES

MODEL NAME	MODEL NUMBER	MODEL SIZE (in.)	COVERAGE (sq. ft.)
FloodVENT®	1540-520	15 <sup>3</sup> / <sub>4</sub> " X 7 <sup>3</sup> / <sub>4</sub> "	200
SmartVENT®	1540-510	15 <sup>3</sup> / <sub>4</sub> " X 7 <sup>3</sup> / <sub>4</sub> "	200
FloodVENT® Overhead Door	1540-524	15 <sup>3</sup> / <sub>4</sub> " X 7 <sup>3</sup> / <sub>4</sub> "	200
SmartVENT® Overhead Door	1540-514	15 <sup>3</sup> / <sub>4</sub> " X 7 <sup>3</sup> / <sub>4</sub> "	200
Wood Wall FloodVENT®	1540-570	14" X 8 <sup>3</sup> / <sub>4</sub> "	200
Wood Wall FloodVENT® Overhead Door	1540-574	14" X 8 <sup>3</sup> / <sub>4</sub> "	200
SmartVENT® Stacker	1540-511	16" X 16"	400
FloodVent® Stacker	1540-521	16" X 16"	400

For SI: 1 inch = 25.4 mm; 1 square foot = m<sup>2</sup>



**ICC-ES Evaluation Report****ESR-2074 FBC Supplement**

Reissued February 2015

Revised March 2016

*This report is subject to renewal February 2017.*

---

**www.icc-es.org | (800) 423-6587 | (562) 699-0543** A Subsidiary of the International Code Council®

---

**DIVISION: 08 00 00—OPENINGS**  
**Section: 08 95 43—Vents/Foundation Flood Vents****REPORT HOLDER:****SMARTVENT PRODUCTS, INC.**  
430 ANDBRO DRIVE, UNIT 1  
PITMAN, NEW JERSEY 08071  
(877) 441-8368  
[www.smartvent.com](http://www.smartvent.com)  
[info@smartvent.com](mailto:info@smartvent.com)**EVALUATION SUBJECT:****SMART VENT® AUTOMATIC FOUNDATION FLOOD VENTS: MODELS #1540-520; #1540-521; #1540-510; #1540-511; #1540-570; #1540-574; #1540-524; #1540-514****1.0 REPORT PURPOSE AND SCOPE****Purpose:**

The purpose of this evaluation report supplement is to indicate that Smart Vent® Automatic Foundation Flood Vents, recognized in ICC-ES master report ESR-2074, have also been evaluated for compliance with the codes noted below.

**Applicable code editions:**

- 2014 Florida Building Code—Building (FBC)
- 2014 Florida Building Code—Residential (FRC)

**2.0 CONCLUSIONS**

The Smart Vent® Automatic Foundation Flood Vents, described in Sections 2.0 through 7.0 of the master evaluation report ESR-2074, comply with the FBC and the FRC, provided the design and installation are in accordance with the *International Building Code*® provisions noted in the master report.

Use of the Smart Vent® Automatic Foundation Flood Vents has also been found to be in compliance with the High-Velocity Hurricane Zone provisions of the FBC and the FRC.

For products falling under Florida Rule 9N-3, verification that the report holder's quality assurance program is audited by a quality assurance entity approved by the Florida Building Commission for the type of inspections being conducted is the responsibility of an approved validation entity (or the code official when the report holder does not possess an approval by the Commission).

This supplement expires concurrently with the master report, reissued February 2015 and revised May 2016.

DETAIL DIAGRAM  
 MODEL 1540-510 & 1540-520

DUAL FUNCTION FLOOD AND VENTILATION VENT & FLOOD VENT INSULATED

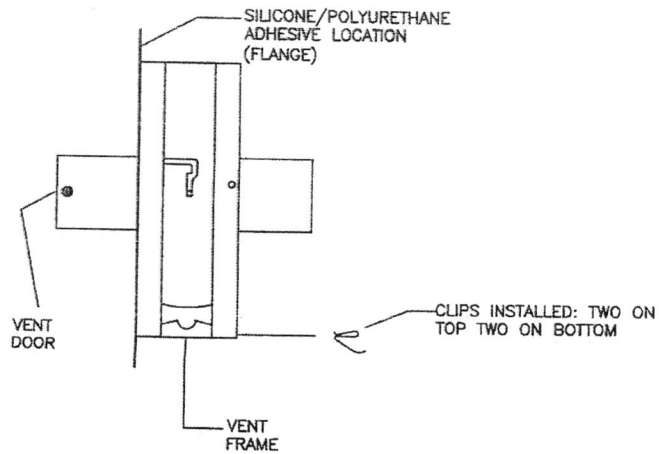
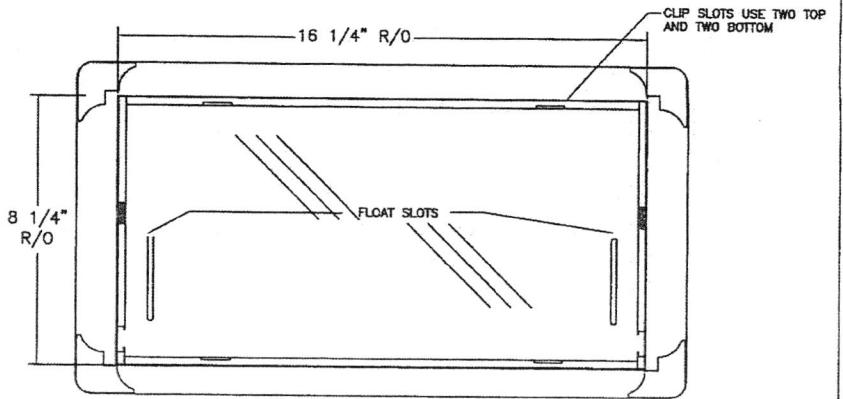
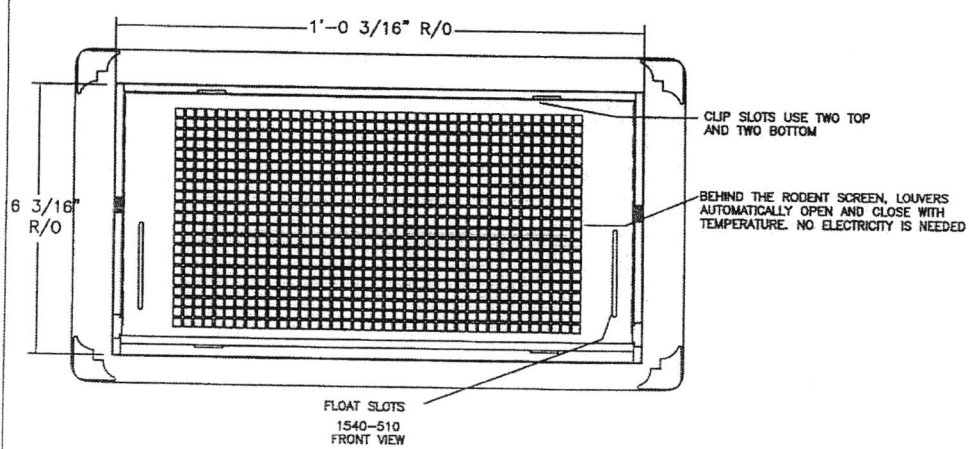

FIGURE 2  
SIDE VIEW

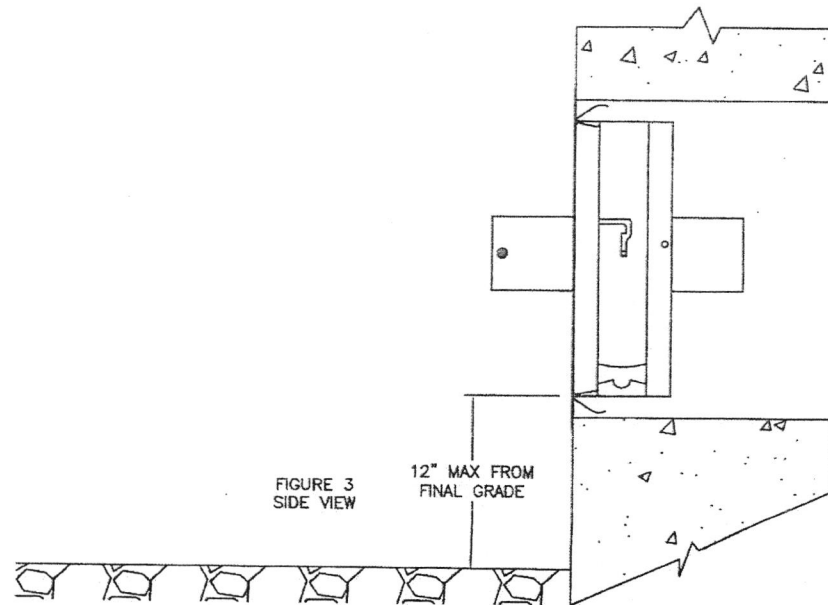



FIGURE 3  
SIDE VIEW

 <b>SMART VENT®</b> 877-441-8368 WWW.SMARTVENT.COM		SMART VENT Foundation Flood Vents 430 AndBro Dr., Unit 1 Pitman NJ 08071	
		DUAL FUNCTION FLOOD AND VENTILATION VENT & INSULATED FLOOD VENT MODEL 1540-510 & 1540-520	
SIZE A	DWG NO. 1540-510 & 1540-520	REV A	
DATE: 6-21-16		SHEET 1 OF 2	